

SWASTIK

ESTABLISHED 1937

CONTINUOUS OPEN-WIDTH BLEACHING RANGES (PRE-TREATMENT RANGES)



Range Commissioned in 2005

SWASTIK TEXTILE ENGINEERS PVT. LTD.

Swastik Premises, Amraiwadi, Ahmedabad - 380 026. INDIA

Tel. : (+91)(79) 2274 3553, 2274 9068, 2274 8551, 5543 5017 **Fax :** (+91) (79) 2274 9131

e-mail : info@swastik.in

www.swastik.in

For more than 45 years **SWASTIK** has been engaged in manufacturing Wet Processing and Finishing Equipments. SWASTIK has been pioneering the designing and manufacturing of modern and latest equipment in India, be it a Continuous Dyeing Plant; a Loop Steamer; a Rotary Screen Printing Machine or a Compressive Shrinking Range. Therefore it was not a coincidence that in 1978, SWASTIK was the first Indian manufacturer to launch the Open Width Pre-Treatment Range with Combi-Steamer, a concept which had been adopted internationally. The present Open Width Scouring and Bleaching installations offered by SWASTIK can claim considerable economical and technical advantages. The first continuous Bleaching Plant with Combi-Steamer has now been in operation for over 27 years.

IMPREGNATOR

Impregnators for the Pre-Treatment Range are designed for M.A.T. and equipped with Wiper Rollers of suitable rubber to obtain high pick-up of 100% or more upto 120-130%.

For specific quality of fabrics, a vacuum slot can be located at the entry of the fabrics to the Impregnator from the preceding Hi-Squeeze Nip.

Fabric from Vacuum Slot / Hi-Squeeze Nip passes through the trough with minimum liquor for light interchange dip before being subjected to a spray of chemicals with desired concentration and quality with the help of a well designed, fully automatic dosing system.

A set of Wiper Rollers are provided to enable uniform add on as may be required.

Chemical Dosing: **SWASTIK** Pre-Treatment Ranges are equipped with Metering Pumps of suitable capacity to deliver the chemicals to the Impregnator in proportion to the volume based on fabric weight (mtr./kg. or g.s.m.) and pickup. These metering pumps are controlled through a PLC or Microprocessor. A Stainless Steel recirculating pump is provided to circulate the liquor through the mixing tank.

SWASTIK Pre-Treatment Ranges can be equipped with an Impregnator with possibility of extended dwell time with Impregnating length of about 16-20 meters, which permits higher liquor exchange at high speeds even in heavy fabrics. The Impregnator is suitable for Woven and Open Knit Fabrics and can be used for individual chemical impregnation or for a combined process, which results in better absorbency on the fabrics with higher whiteness.

Impregnator can be provided with Tension Control Devices (Load Cells) to process fabrics with desired tension.

MAIN FEATURES

Flexibility: The **SWASTIK** Pre-Treatment Range is carefully engineered and of robust construction and uses standardized components. The salient features are minimal and controlled cloth tension, optimum attainable absorption of chemicals and low power and utilities consumption .

SWASTIK offers the Pre-Treatment Range in single or multiple stages and in combination with various units to cater to small production of 30,000 meters to a full size range for a production of 100,000 meters per day. SWASTIK also offers a complete range from Singeing and Desizing to Bleaching in a single line.

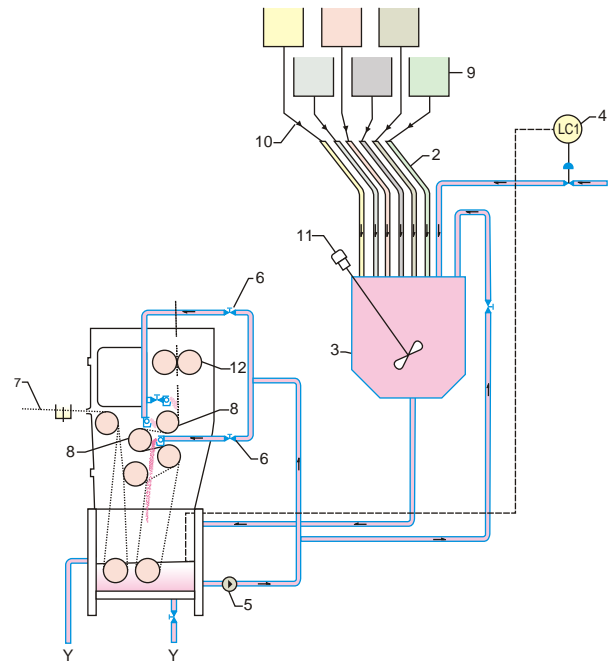

Sr. No.	Description	Sr. No.	Description
1	Fresh Water	7	Fabric
2	Chemical Feeding Line	8	Impregnating Rollers
3	Mixing Tank	9	Storage Tanks
4	Level Indicator	10	Dosing Pumps
5	Circulation Pump	11	Slow Speed Stirrer
6	Regulator	12	Wiper Roller

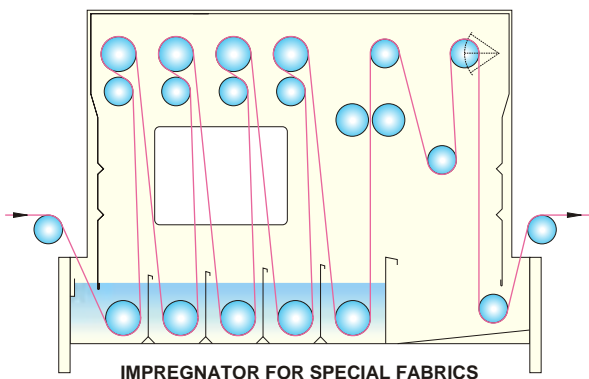

The **SWASTIK** Roller Bed Combi-Steamer (with Horizontal and vertical tight Strands) is designed keeping in view present day needs - a multi-purpose reaction chamber for a continuous Fabric Treatment Range for all kinds of fabric.

The Combi-Steamer is provided with a steam lock at the fabric entry and a Water Seal arrangement at the delivery. Fabric is fed from the bottom, through the steam-seal, using the 'STEAM DOME' Principle. Air Vents are provided to remove air from the Steamer to make it absolutely air free which ensures lower steam consumption and optimum fabric temperature.

STEAMERS

SWASTIK offers Steamers of various capacities and configurations to suit different application for the Pre-Treatment Ranges using the most modern technology for Tension Controls with Tension Sensing and regulating devices using AC Inverter Drives. Steamers are provided with large diameter rollers for the tight strand and low weight rollers for the Roller Bed Conveyor. Steam is fed through a steam conditioning unit ensuring saturated steam inside the steamer.

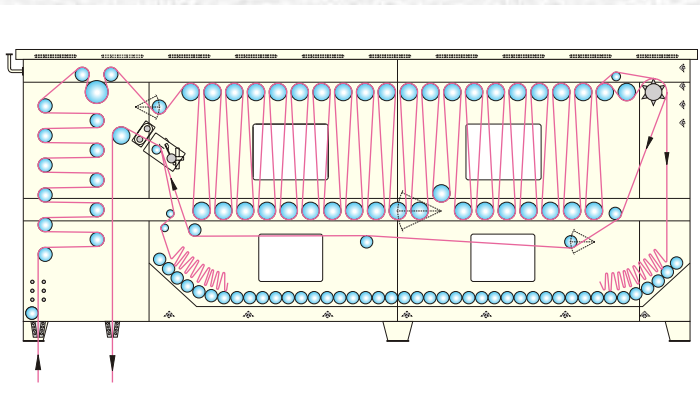

TIGHT STRAND PASSAGE

Fabric delivered through the wiper rollers is guided to the Combi-Steamer through a Steam-Lock to maintain air-free atmosphere in the steamer. A small horizontal run on tight strands, ideally suited for M.A.T., precedes the larger tight strand section.

Tight strand passage is provided with single or double loop threading, depending upon capacity requirements with multiple sections having a total 60 meters to 240 meters holding capacity giving recipe-related dwell times from 1 minute to 10 minutes on the tight strand. The unit is complete with Tension Control devices acting on Frequency Controlled AC Drive of each section.

STEAM CONDITIONING SYSTEM

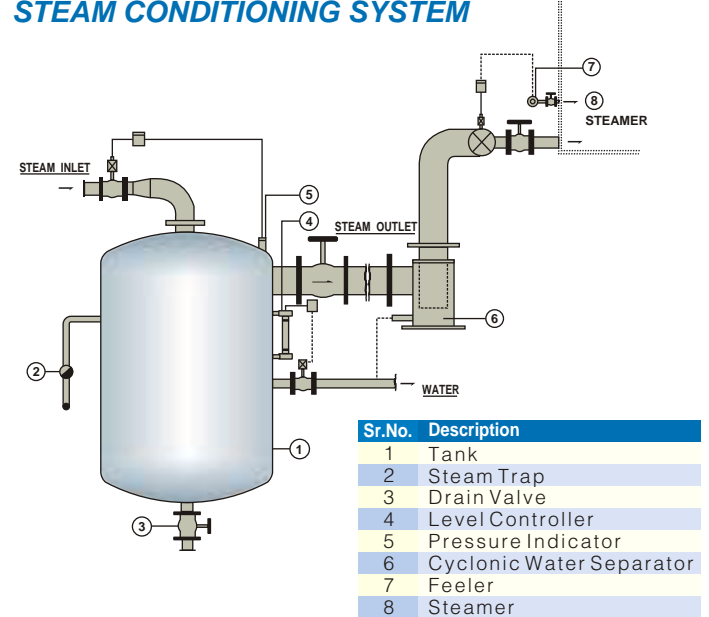

ROLLER BED CONVEYOR PASSAGE

A Roller Bed Conveyor consisting of a row of positively driven Stainless Steel Rollers, transports the fabric in small loops from one end to the other in absolutely relaxed condition for a pre-determined dwell time varying from 10 to 40 minutes or more, as may be required. Holding capacity varies from 900 meters to 1800 meters depending upon the number of sections.

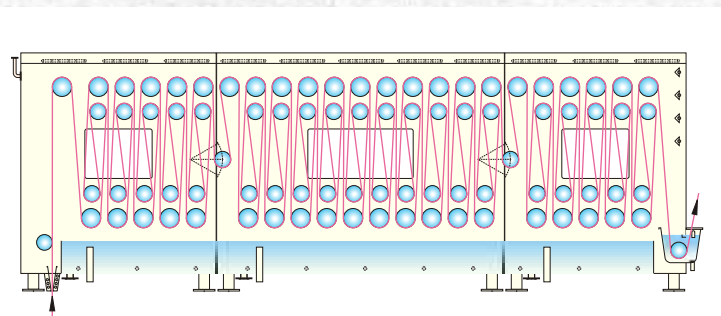
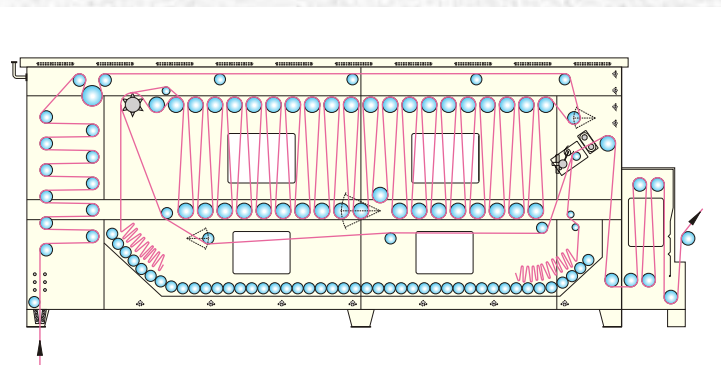

For Continuous Desizing, **SWASTIK** offers a Steamer with capacities ranging from 60 meters to 240 meters and with two different systems. One can choose a Steamer with Wet Steam Generation inside the Steamer or a Steamer with Steam Conditioning Unit placed outside the Steamer. Both Steamers can be with single cloth threading or double cloth threading depending upon capacity requirement, space available and quality of fabrics. For specific requirements, a roller bed conveyor can also be incorporated.

CONTINUOUS DESIZING AND BLEACHING RANGE

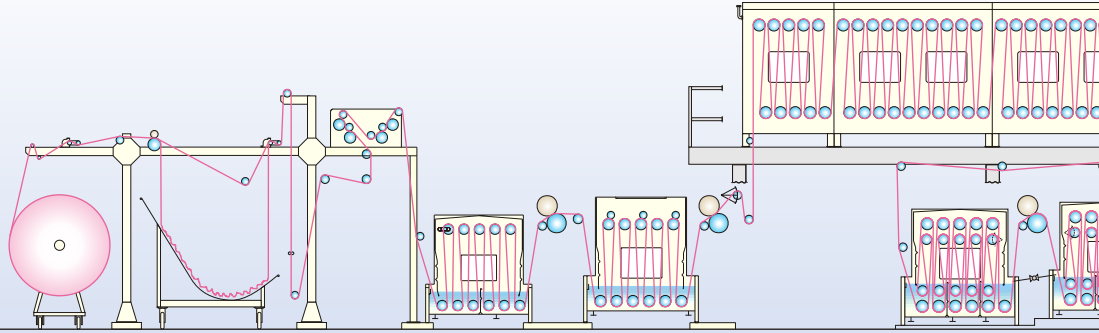

CONTINUOUS PRE-TREATMENT RANGE WITH ELEVATED COMBI STEAMER

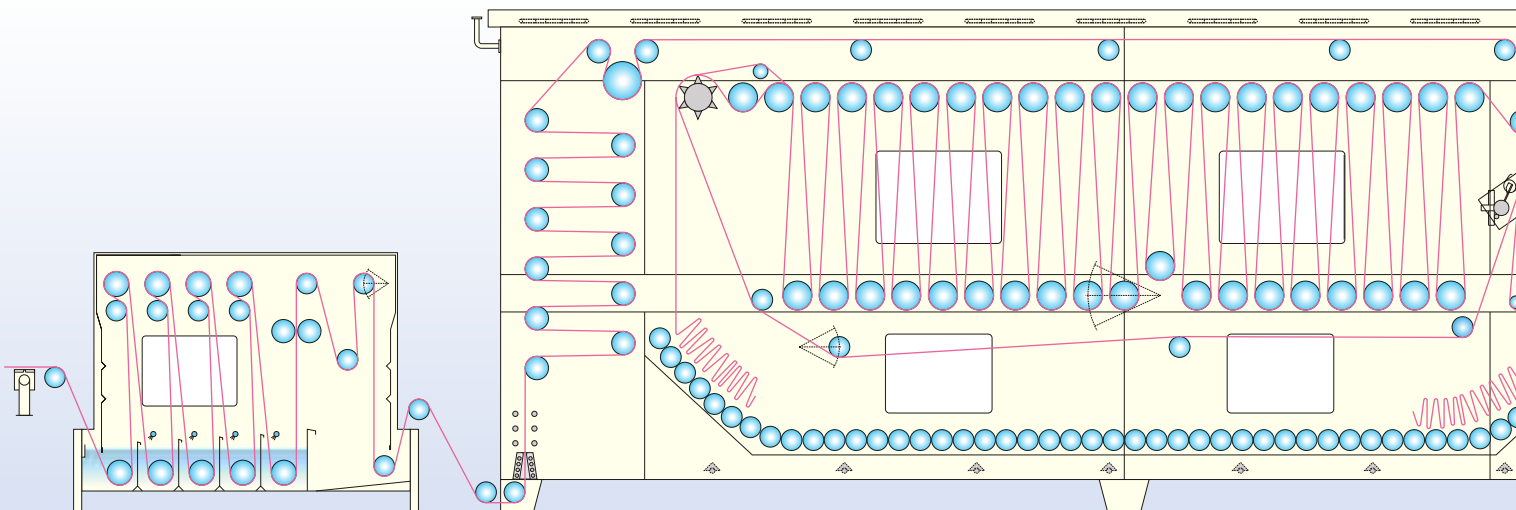
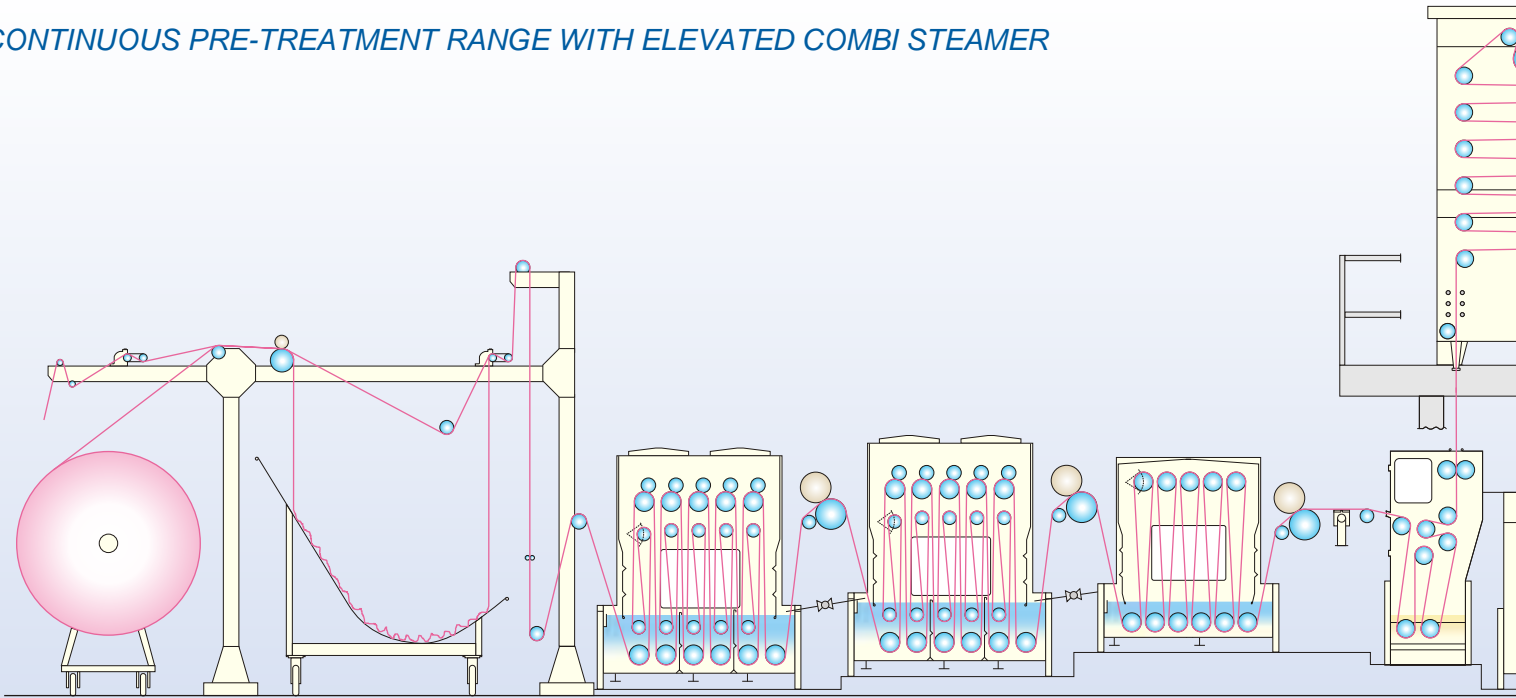

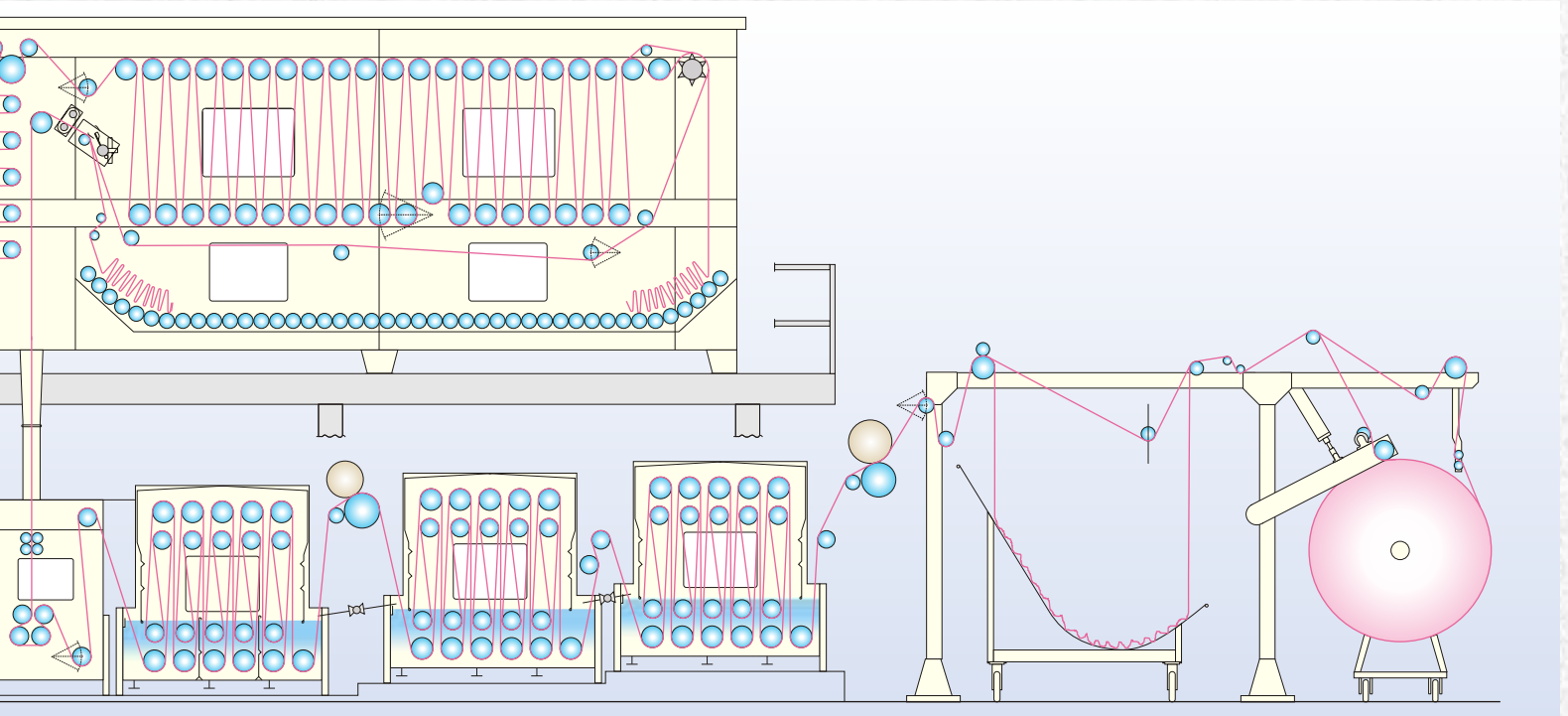
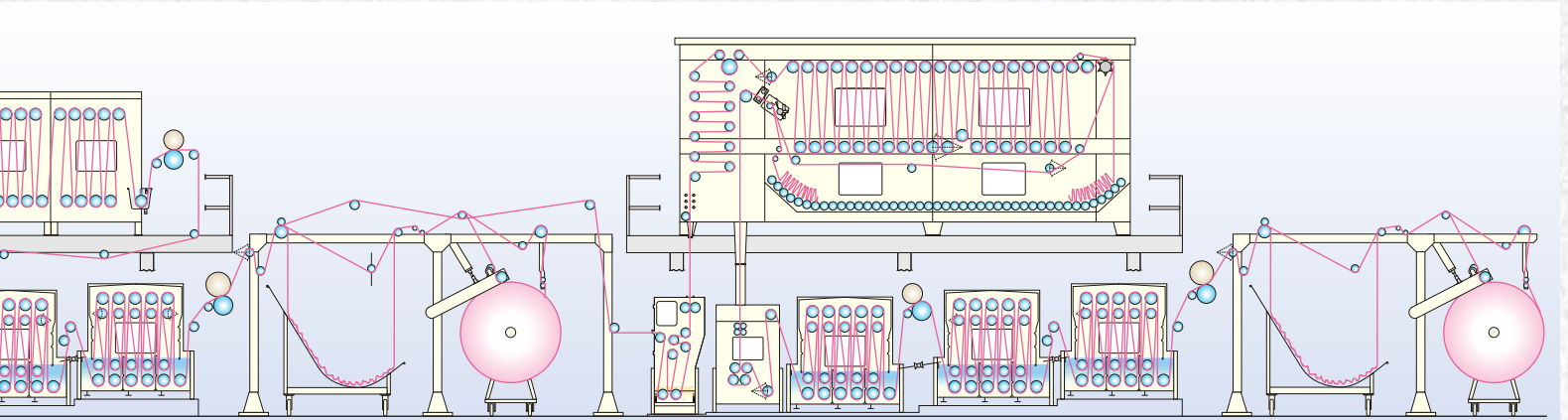

CONTINUOUS PRE-TREATMENT RANGE WITH HYDROTEX WASHERS

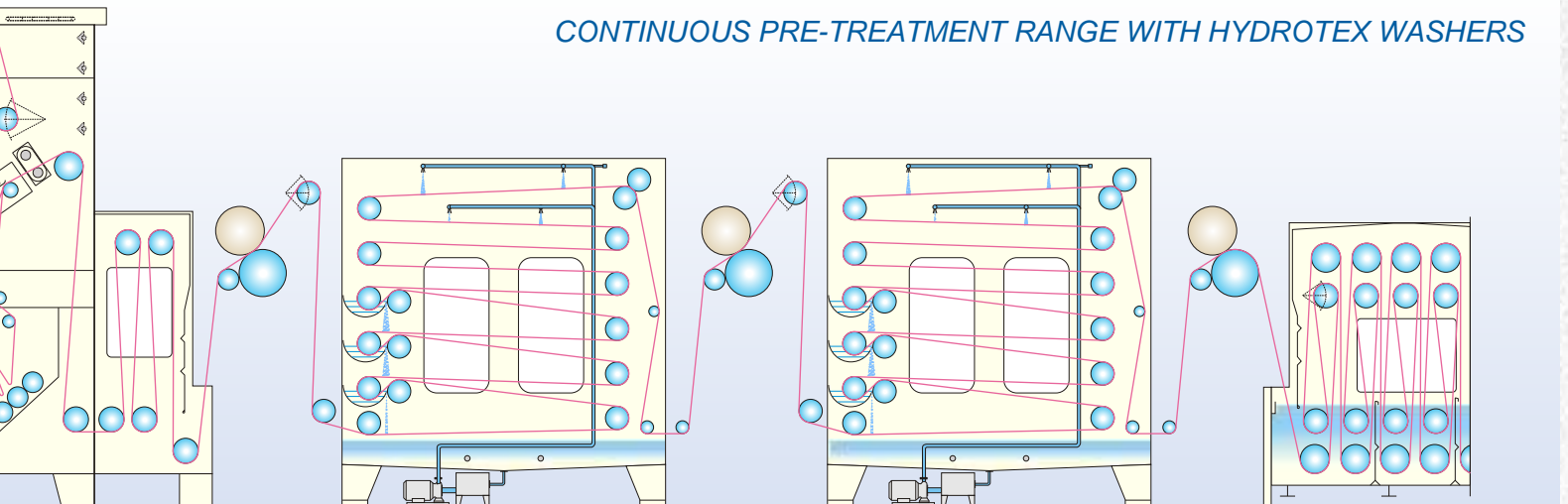

COMBI-STEAMER : REACTION TIME - SPEED CHART

Speed	40 Mts/Min.	60 Mts/Min.	75 Mts/Min.
1200/60 mts. Single Loop	30/1.5	20/1.00	---
1200/100 mts. Double Loop	30/2.5	20/1.66	16/1.33
1500/90 mts. Single Loop	37.5/2.25	25/1.5	20/1.2
1500/150 mts. Double Loop	37.5/3.75	25/2.5	20/2.0
1800/120 mts. Single Loop	---	30/2	24/1.6
1800/200 mts.	---	30/3.3	24/2.66

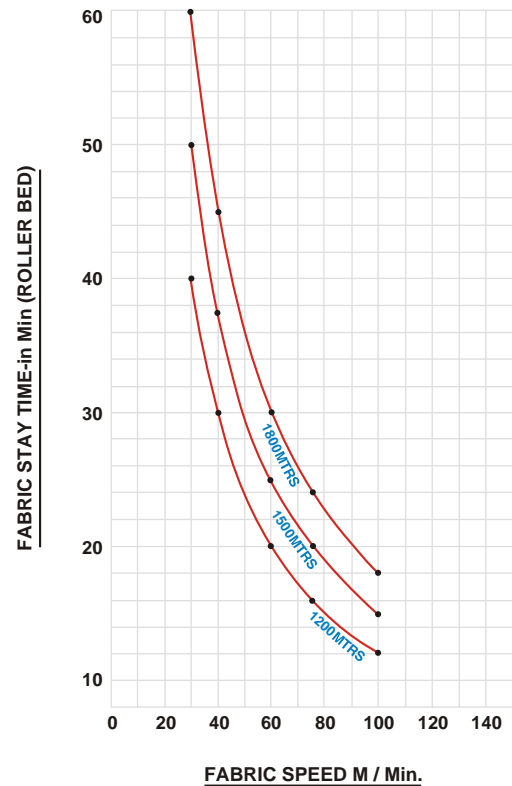
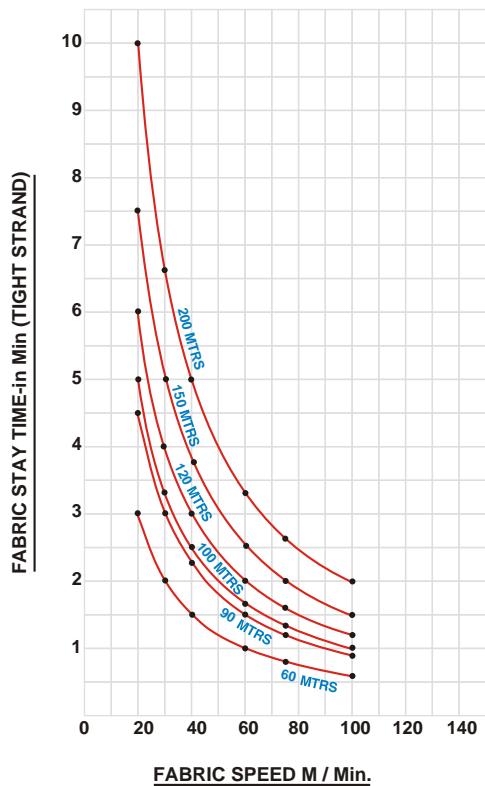

WASHING

Fabric outlet from the Combi-Steamer is through a Stainless Steel Washing System where ceaseless fabric coming out from the Combi-Steamer passes on to a Wash Tank through a water seal arrangement without coming in contact with air and without losing heat. This helps wash fabric impurities / effluents efficiently at almost reaction temperature and effectively prevents possibility of coagulation of saponified waxes or emulsified impurities.

SWASTIK offers different types of Wash Boxes depending upon quality and construction of fabrics and production requirement.

A combination of closed Washing Compartments comprising wash boxes model STN-15, STN-18, STN-21 with single threading; Closed Washing Compartment STN-20 or STN-25 with counter current threading with large diameter rollers and Spray Jets or STN-25CP with small pneumatically loaded squeeze rolls on all Top Rollers but without Spray Jets, follow the Steamer.

For most efficient performance, a Washing Compartment "Hydrojet" with horizontal fabric passage equipped with special Spray Jets can be used immediately after the fabric exits the Steamer.

All Wash Tanks can be equipped with Direct / Indirect Heating arrangements with Temperature Controllers, water & management, flow control valves, Tension control Devices, etc

The number and type of Washing Tanks to be installed depend upon production requirements and fabric quality.

For further details of Washing Tanks, please see our brochure of Washing Ranges.

AUTOMATION

SWASTIK has developed a sophisticated and modern programming system which ensures optimum production in the Pre-Treatment Ranges (Scouring and Bleaching Lines). The level of Automation can be designed for specific requirements of individual customers. Typical level of automation in our standard range could be as follows.

Access and Control of basic machine parameters, functions and displays using **PLC / Micro Processor**.

- ▶ Speed and tension
- ▶ Process Control
- ▶ Liquor / Water Flow Management
- ▶ Level controls
- ▶ Automatic Dosing Control
- ▶ Squeeze Pressure Control
- ▶ Dwell Time Control
- ▶ Chemical Dosing at various stages
- ▶ Recipe editing and Control
- ▶ Temperature control
- ▶ Fabric Tension Control
- ▶ Level and Pressure Controller for Steam Conditioning Unit of Combi-Steamer etc.



TECHNICAL DATA

ROLLER FACE	1600 mm - 3800 mm
FABRIC WIDTH	1400 mm - 3600 mm
IMPREGNATOR	As per MAT Application OR Special Execution for longer Impregnating time for heavy Fabrics
DOSING SYSTEM	Multipoint, fully automatic Dosing System
COMBI-STEAMER CAPACITY	Tight Strand - Horizontal 10 meters - Vertical 60 meters - 200 meters Roller Bed Conveyor - 900 - 1800 meters on request up to 3000 meters or more
SPEED RANGE	15 to 80 meters / minute
DRIVE	<ul style="list-style-type: none"> ▶ AC Frequency Controlled Drive using tension control devices at various stages. ▶ Intermediate Squeezer Motors ▶ Tight Strand Section Motors ▶ Conveyor Motor ▶ Final Squeezer ▶ Tension Control on Tight Strand - Load Cells ▶ Pump Motors



Range Commissioned in 1998

manufactured by

SWASTIK TEXTILE ENGINEERS PVT. LTD.

marketing &
servicing agents

SHREEJI ENGINEERING & MARKETING SERVICES

Swastik Premises, Amraiwadi, Ahmedabad - 380 026. INDIA

Tel. : (+91)(79) 2274 3553, 2274 9068, 2274 8551, 5543 5017 **Fax :** (+91) (79) 2274 9131

e-mail : info@swastik.in

www.swastik.in

Mumbai Office : 11, Sir Vithaldas Chambers, 16, Mumbai Samachar Marg, Fort, Mumbai - 400 023. INDIA

Tel. : (+91) (22) 2204 9812 **Fax :** (+91) (22) 2288 1481